

TO BE USED FOR THE PURPOSES OF THE NATIONAL BUREAU OF STANDARDS...  
...THESE TESTS ARE TO BE PERFORMED IN ACCORDANCE WITH THE...  
...STANDARDS AND PROCEDURES OF THE NATIONAL BUREAU OF STANDARDS...  
...AS APPLICABLE TO THE NATIONAL BUREAU OF STANDARDS AS APPLICABLE...

This procedure is provided for customers whose products require  
inspection test be performed in accordance with the  
may be accepted

# 29B ACCEPTANCE TEST PROCEDURE

981-0201-001

AUGUST 85

Copyright © 1985 Data I/O Corporation. All rights reserved.

981-0201-001

The 29B acceptance test consists of a power-up self-test, described in section 3, and a power supply check at several test points on the control board.

WARRANTY

DATA I/O CORPORATION WARRANTS TO THE ORIGINAL PURCHASER OF THE PRODUCT DESCRIBED BY THE 29B UNIVERSAL PROGRAMMER OPERATOR'S MANUAL THAT THE PRODUCT WAS FULLY FUNCTIONAL TO THE EXTENT OF ITS SPECIFICATION AT THE TIME OF SHIPMENT FROM THE FACTORY. DATA I/O FURTHER CERTIFIES THAT THE TEST EQUIPMENT USED TO TEST THE PRODUCT WAS CALIBRATED TO STANDARDS THAT ARE TRACEABLE TO THE NATIONAL BUREAU OF STANDARDS AS APPROPRIATE.

#1 Parallel-ported programmer  
The 29B programmer was tested prior to shipment and was mechanically inspected and carefully packaged to prevent shipping damage. It should arrive free of any damage, and in good operating condition. However, carefully inspect the unit for any damage that may have occurred during shipment.

The 29B programmer was tested prior to shipment and was mechanically inspected and carefully packaged to prevent shipping damage. It should arrive free of any damage, and in good operating condition. However, carefully inspect the unit for any damage that may have occurred during shipment.

This procedure is provided for customers whose company policy requires that an inspection test be performed before the unit may be accepted.

29B  
ACCEPTANCE TEST  
PROCEDURE

AUGUST 1981  
Copyright © 1981 Data I/O Corporation. All rights reserved.

Applies to Engineering Part Number 990-0013-029 and up

## 1. INTRODUCTION

### WARNING

The procedures described in this document are for qualified service personnel only. Do not attempt to perform these procedures unless you are qualified to do so.

The 29B acceptance test consists of a power-up self-test, described in section 3, and a power supply check at several test points on the controller board, described in section 4. Some disassembly is required to perform these procedures.

The following is a list of equipment you will need to perform the acceptance test procedures.

Your 29B programmer was tested both electrically and mechanically before it was shipped, and was carefully packaged to prevent shipping damage. It should arrive free of any defect, without marks or scratches, and in perfect operating condition. However, carefully inspect the unit for any damage that may have occurred in transit. If you note any damage, file a claim with the carrier and notify your nearest Data I/O Service Center. A list of Service Centers is located at the back of the 29B Universal Programmer Operator's Manual.

- #1 Phillips-head screwdriver
- 3 1/2 digit digital multimeter (DMM). The dcV accuracy of the DMM must be  $\pm 0.25\%$  or better.
- Jumper wire, approximately 12 inches long

## 2. 29B DISASSEMBLY

In order to perform the acceptance test procedures, you must first remove the 29B's top cover and protective shield as described in the following subsections.

### 2.1 Top Cover Removal

#### WARNING

To avoid electrical shock, disconnect the power cord before removing the top cover or protective shield.

1. With the power cord disconnected, the programmer's power off, and no programming Pak installed in the programmer, turn the programmer upside down and remove the four screws at the corners of the base.
2. Holding the cover in place, return the programmer to its upright position.
3. Remove the top cover by lifting it straight up. This step will expose the front portion of the controller board (see figure 1).

### 2.2 Controller Board Protective Shield Removal

The controller board protective shield is a plastic plate located below the opening in the 29B's front panel (see figure 1). Remove the protective shield as directed in the following steps.

1. With a flat-head screwdriver, push the shield back and pull it up to clear it from the lips at the Pak connector. (You may wish to loosen the two screws holding the vertical shield in place at the back of the controller board protective shield to make the protective shield removal easier.)

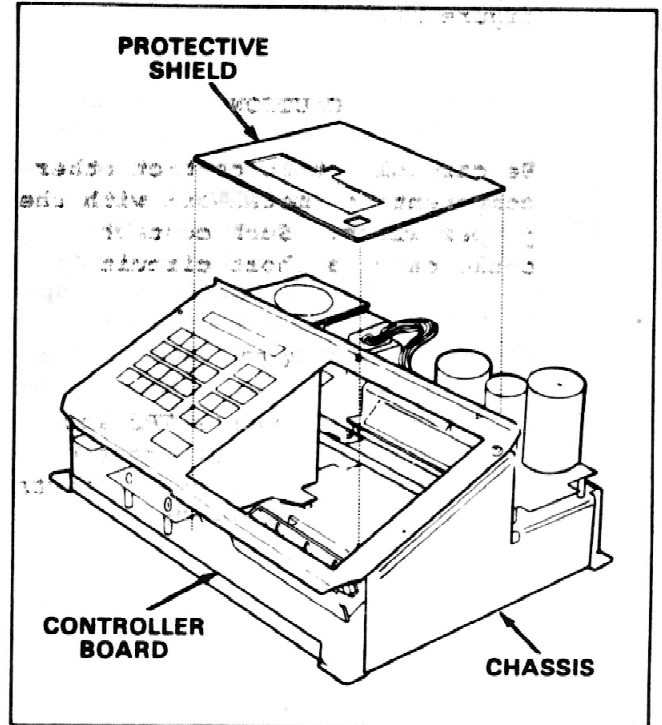

Figure 1. Protective Shield Removal

2. Lift the back edge of the shield out, pull it up slightly and carefully turn it to the left until it clears the opening on the programmer's front panel. Pull the shield out of the programmer.

You are now ready to perform the acceptance test procedures.

3. **POWER-UP SELF-TEST**

To power-up the 29B programmer and cause it to perform its self-test, perform the following procedures:

1. With the jumper wire, jumper test points TP2 and TP3, near the front edge of the controller board (see figure 2).

**CAUTION**

Be careful not to contact other components or metalwork with the jumper wires. Such contact could cause a short circuit.

**NOTE**

Jumpering test points TP2 and TP3 allows you to perform the self-test and power supply tests without installing a Pak.

2. Connect your DMM to ground at TP2 (see figure 2).
3. Plug the AC power cord into the rear of the programmer and into a power outlet.

4. Press the power switch on the back of the programmer up to the "ON" position. The programmer will display

SELF TEST 

and the "hand" of the action symbol at the right side of the display will rotate.

When the self-test completes, the programmer will display

SYSTEM 29B VNN

"VNN" is the version number of the firmware installed in the programmer.

If the self-test completes with no errors, proceed to the next section.

If the self-test fails or the self-test message is not displayed, turn the programmer power off. Check to make sure that TP2 and TP3 are jumpered together properly. Turn the programmer power on again. If the self-test fails again, contact your nearest Data I/O Service Center.

#### 4. POWER SUPPLY TEST

The final acceptance test procedure is to measure the power supplies at test points on the controller board.

With the DMM, measure the power supplies at the test points listed in table 2. The voltages of these test points should fall within the ranges listed in table 2. The location of the test points are shown in figure 2.

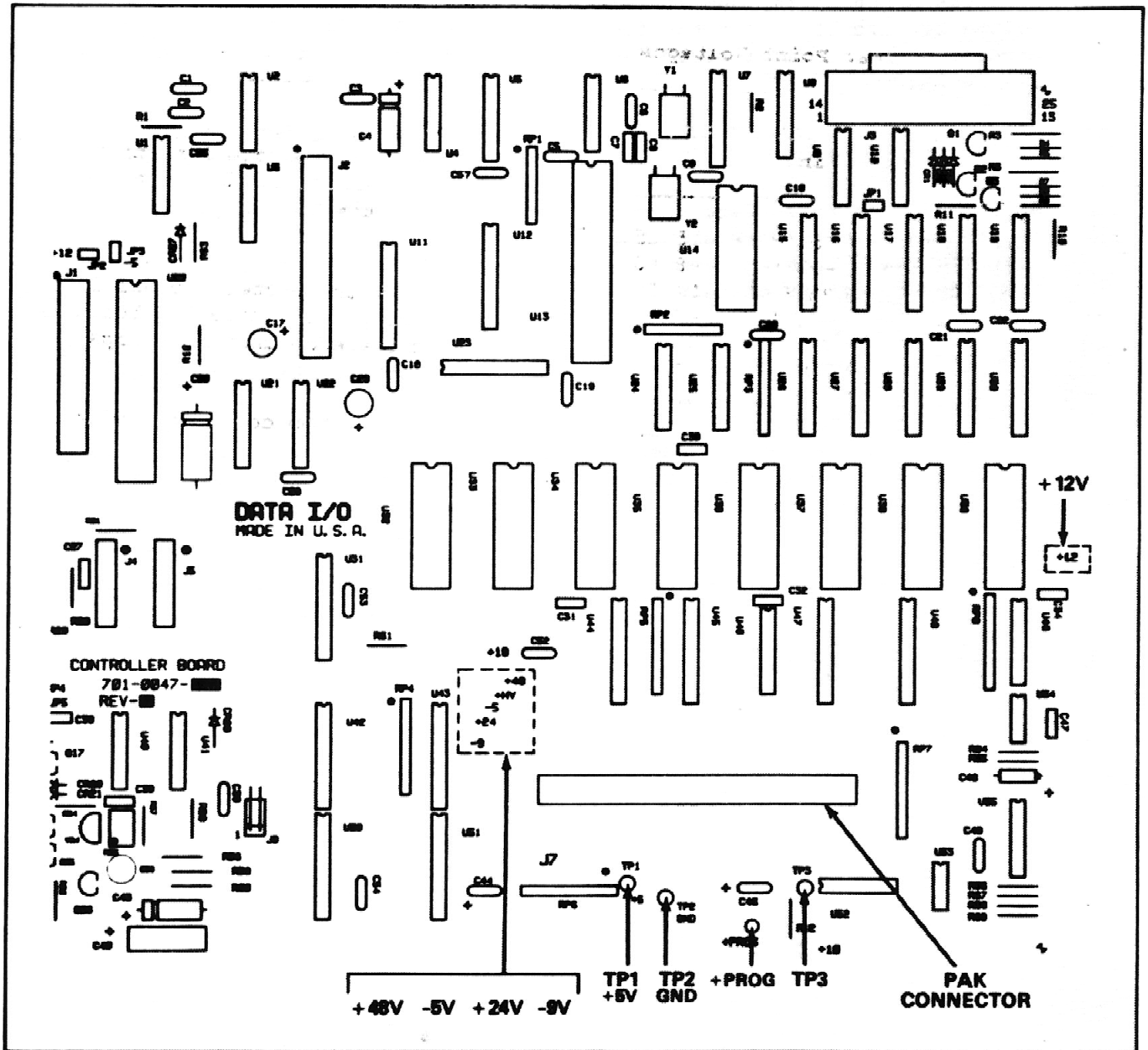

Figure 2. Test Point Locations

## WARNING

High voltages are present on the controller board which could be hazardous. Exercise extreme caution while making the following measurements. Do not touch the circuit board with a non-insulated tool or your hands.

Table 2. Test Point Voltages

POWER SUPPLY	VOLTAGE RANGE	
	Min.	Max.
+5 V (TP1)	5.08	5.15
-9 V	-9.20	-8.80
+24 V	23.5	24.5
-5 V	-5.25	-4.75
+48 V	49.5	49.8
+PROG V	4.80	5.11
+12 V	11.4	12.6

If the voltages of all of the test points fall within the ranges listed in table 2, reassemble the programmer as described in section 5.

If the voltage of one or more of the test points falls outside of the range listed in table 2, contact your nearest Data I/O Service Center.

If all of the test procedures were completed successfully, the acceptance test procedure is complete.

## 5. 29B REASSEMBLY

1. Turn the programmer power off and unplug the power cord from the programmer.
2. Disconnect the DMM from TP2.
3. Disconnect the jumper wire from TP2 and TP3.

### CAUTION

Remove the jumper wire jumpering TP2 and TP3 before inserting a Pak. Failure to do so could damage the Pak.

4. Replace the protective shield covering the controller board and lock the edge under the lips at the Pak connector.
5. Slide the top cover into place.
6. Holding the top cover in place, turn the programmer upside down and replace the four screws at the corners of the base.
7. Return the programmer to its upright position.

Reassembly is now complete.